

**WARREN  
RUPP®**

Quality System  
ISO9001 Certified

Environmental  
Management System  
ISO14001 Certified

**IDEX**  
IDEX CORPORATION

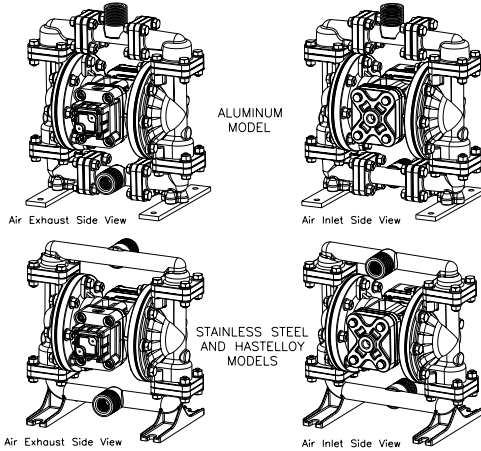

U.S. Patent #5,996,627; 6,241,487  
Other U.S. Patents Applied for

# SandPIPER II®

## S05 Metallic Design Level I Ball Valve

### Air-Powered Double-Diaphragm Pump



ENGINEERING, PERFORMANCE  
& CONSTRUCTION DATA

INTAKE/DISCHARGE PIPE SIZE	CAPACITY	AIR VALVE	SOLIDS-HANDLING	HEADS UP TO	DISPLACEMENT/STROKE
½" NPT or ½" BSPT (internal) 1" NPT or 1" BSPT (external)	0 to 15 gallons per minute (0 to 56 liters per minute)	No-lube, no-stall design	Up to .125 in. (3mm)	125 psi or 289 ft. of water (8.6 Kg/cm <sup>2</sup> or 86 meters)	.026 Gallon / .098 liter

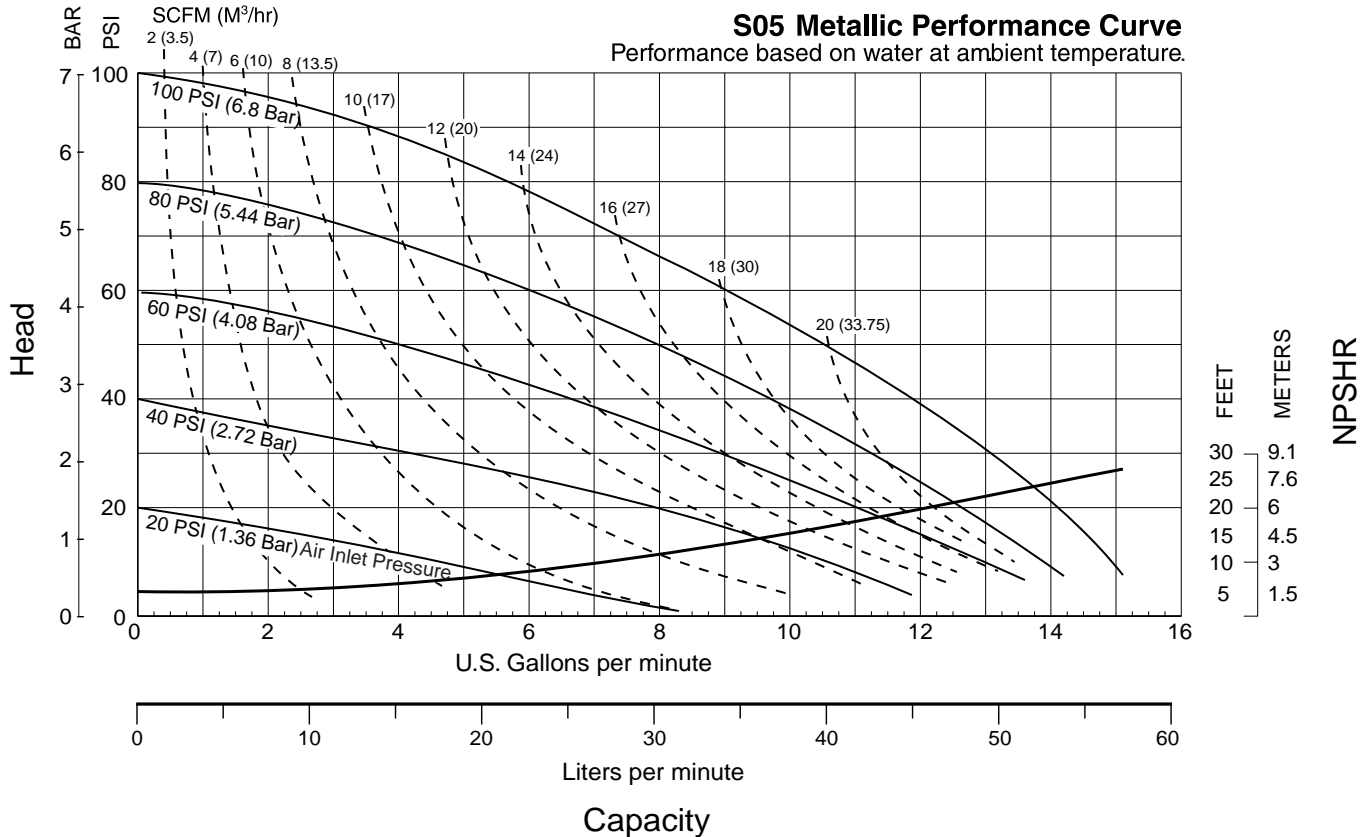

SandPIPER II® pumps are designed to be powered only by compressed air.

# Explanation of Pump Nomenclature

## S05 Metallic - Design Level 1- Ball Valve

MODEL	Pump Brand	Pump Size	Check Valve Type	Design Level	Wetted Material	Diaphragm/ Check Valve Materials	Check Valve Seat	Non-Wetted Material Options	Porting Options	Pump Style	Pump Options	Shipping Kit Options	Weight lbs. (kg)
S05B1ABWPNS000.	S	05	B	1	A	B	W	P	N	S	0	00.	15 (7)
S05B1ACTPNS000.	S	05	B	1	A	C	T	P	N	S	0	00.	15 (7)
S05B1AEWPNS000.	S	05	B	1	A	E	W	P	N	S	0	00.	15 (7)
S05B1ANWPNS000.	S	05	B	1	A	N	W	P	N	S	0	00.	15 (7)
S05B1AXTPNS000.	S	05	B	1	A	X	T	P	N	S	0	00.	15 (7)
S05B1A1WPNS000.	S	05	B	1	A	1	W	P	N	S	0	00.	15 (7)
S05B1A2TPNS000.	S	05	B	1	A	2	T	P	N	S	0	00.	15 (7)
S05B1SBWPNS000.	S	05	B	1	S	B	W	P	N	S	0	00.	21 (10)
S05B1SCTPNS000.	S	05	B	1	S	C	T	P	N	S	0	00.	21 (10)
S05B1SEWPNS000.	S	05	B	1	S	E	W	P	N	S	0	00.	21 (10)
S05B1SNWPNS000.	S	05	B	1	S	N	W	P	N	S	0	00.	21 (10)
S05B1SXTPNS000.	S	05	B	1	S	X	T	P	N	S	0	00.	21 (10)
S05B1S1WPNS000.	S	05	B	1	S	1	W	P	N	S	0	00.	21 (10)
S05B1S2TPNS000.	S	05	B	1	S	2	T	P	N	S	0	00.	21 (10)
S05B1HBWPNS000.	S	05	B	1	H	B	W	P	N	S	0	00.	23 (11)
S05B1HCTPNS000.	S	05	B	1	H	C	T	P	N	S	0	00.	23 (11)
S05B1HEWPNS000.	S	05	B	1	H	E	W	P	N	S	0	00.	23 (11)
S05B1HNWPNS000.	S	05	B	1	H	N	W	P	N	S	0	00.	23 (11)
S05B1HXTPNS000.	S	05	B	1	H	X	T	P	N	S	0	00.	23 (11)
S05B1H1WPNS000.	S	05	B	1	H	1	W	P	N	S	0	00.	23 (11)
S05B1H2TPNS000.	S	05	B	1	H	2	T	P	N	S	0	00.	23 (11)

### Pump Brand

S=SandPIPER II®

### Pump Size

05=1/2"

### Check Valve Type

B=Ball

### Design Level

1=Design Level

### Wetted Material

A=Aluminum  
H=Hastelloy  
S=Stainless Steel

### Diaphragm Check Ball Materials

1= Santoprene®/Santoprene®  
B=Buna/Buna  
C=Viton/ PTFE  
E=EPDM/EPDM  
N=Neoprene/Neoprene  
X=UniRupp® PTFE/PTFE  
2=PTFE-Santoprene/PTFE

### Valve Seat

A=Aluminum  
C=Cast Iron  
H=Hastelloy  
S=Stainless Steel  
T=PTFE  
W=UHMW Polyethylene

### Non-Wetted Material

P=Polypropylene  
2=Polypropylene & Stainless Steel Hardware

### Porting Options

N=NPT Threads  
B= BSPT (Tapered) Threads  
1= Dual Porting (NPT) (Alum Only)  
2= Top Dual Porting (NPT) (Alum Only)  
3= Bottom Dual Porting (NPT) (Alum Only)  
4= Dual Porting (BSPT) (Alum Only)  
5= Top Dual Porting (BSPT) (Alum Only)  
6= Bottom Dual Porting (BSPT) (Alum Only)

### Pump Style

S=Standard

### Pump Options

0= None  
2= Mesh Muffler

### Kit Options

00.=None  
P0.=0-30VDC Pulse Output Kit  
P1.=Intrinsically-Safe 10-30VDC Pulse Output Kit  
P2.=110/120 or 220/240VAC Pulse Output Kit  
P3.=Intrinsically-Safe 110/120VAC Pulse Output Kit  
P4.=Intrinsically-Safe 220/240VAC Pulse Output Kit  
E0.=Solenoid Kit with 24VDC Coil  
E1.=Solenoid Kit with 24VDC Explosion-Proof Coil  
E2.=Solenoid Kit with 24VAC/12 VDC Coil  
E3.=Solenoid Kit with 24VAC/12VDC Explosion-Proof Coil  
E4.=Solenoid Kit with 110VAC Coil  
E5.=Solenoid Kit with 110VAC Explosion-Proof Coil  
E6.=Solenoid Kit with 220VAC Coil  
E7.=Solenoid Kit with 220VAC Explosion-Proof Coil  
SP.=Stroke Indicator Pins

**CAUTION! Operating temperature limitations are as follows:**

Materials	Operating Temperatures		
	Maximum*	Minimum*	Optimum**
<b>Buna</b> General purpose, oil-resistant. Shows good solvent, oil, water and hydraulic fluid resistance. Should not be used with highly polar solvents like acetone and MEK, ozone, chlorinated hydrocarbons and nitro hydrocarbons.	190°F 88°C	-10°F -23°C	50° to 140°F 10°C to 60°C
<b>EPDM</b> Shows very good water and chemical resistance. Has poor resistance to oil and solvents, but is fair in ketones and alcohols.	212°F 100°C	-10°F -23°C	50° to 212°F 10°C to 100°C
<b>Neoprene</b> All purpose. Resistant to vegetable oil. Generally not affected by moderate chemicals, fats, greases and many oils and solvents. Generally attacked by strong oxidizing acids, ketones, esters, nitro hydrocarbons and chlorinated aromatic hydrocarbons.	170°F 77°C	-10°F -23°C	50° to 130°F 10°C to 54°C
<b>Santoprene®</b> Injection molded thermoplastic elastomer with no fabric layer. Long mechanical flex life. Excellent abrasion resistance.	212°F 100°C	-10°F -23°C	50° to 212°F 10°C to 100°C
<b>Virgin PTFE</b> Chemically inert, virtually impervious. Very few chemicals are known to react chemically with PTFE: molten alkali metals, turbulent liquid or gaseous fluorine and a few fluoro-chemicals such as chlorine trifluoride or oxygen difluoride which readily liberate free fluorine at elevated temperatures.	212°F 100°C	-35°F -37°C	50°F to 212°F 10°C to 100°C
<b>Viton®</b> Shows good resistance to a wide range of oils and solvents; especially all aliphatic, aromatic and halogenated hydrocarbons, acids, animal and vegetable oils. Hot water or hot aqueous solutions (over 70°F) will attack Viton®.	212°F 100°C	+32°F 0°C	75°F to 212°F 24°C to 100°C
<b>UHMW Polyethylene</b>	180°F 82°C	-40°F -40°C	50°F to 140°F 10°C to 60°C
<b>Polypropylene</b>	150°F 65°C	40°F 5°C	

For specific applications, always consult "Chemical Resistance Chart" Technical Bulletin

\*Definite reduction in service life.

\*\*Minimal reduction in service life at ends of range.

# Dimensions: S05 Metallic (Aluminum Model)

Dimensions in Inches

Dimensional Tolerance:  $\pm 1/8"$

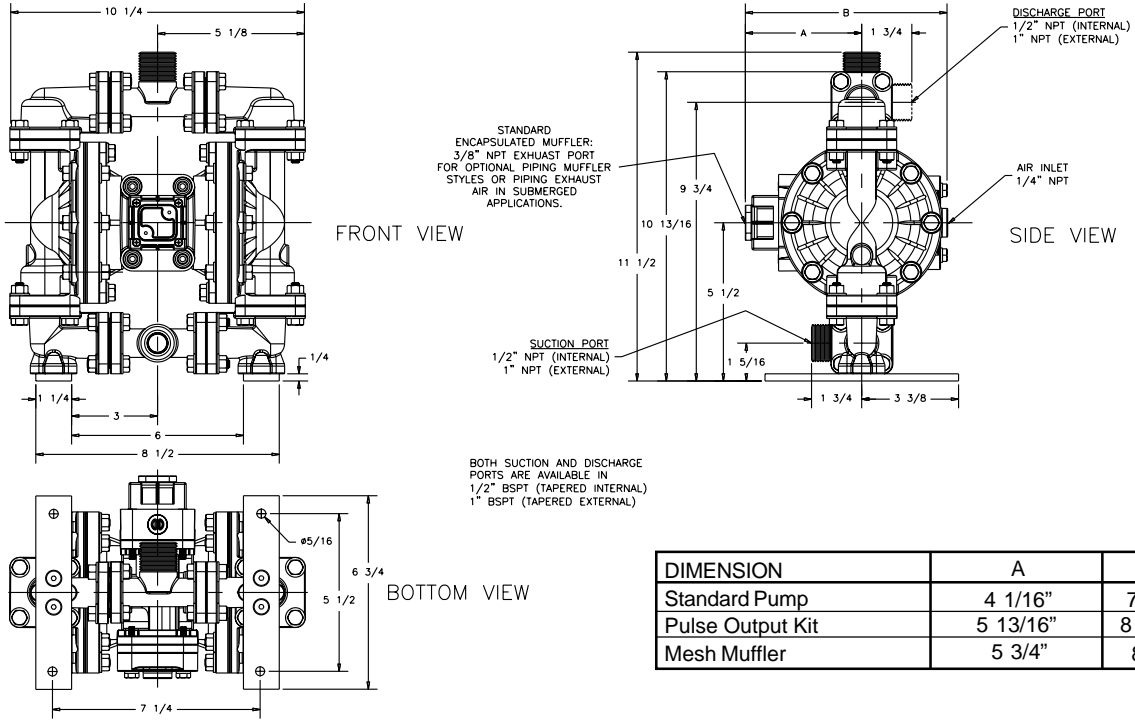

Dimensions in Millimeters

Dimensional Tolerance:  $\pm 3\text{mm}$

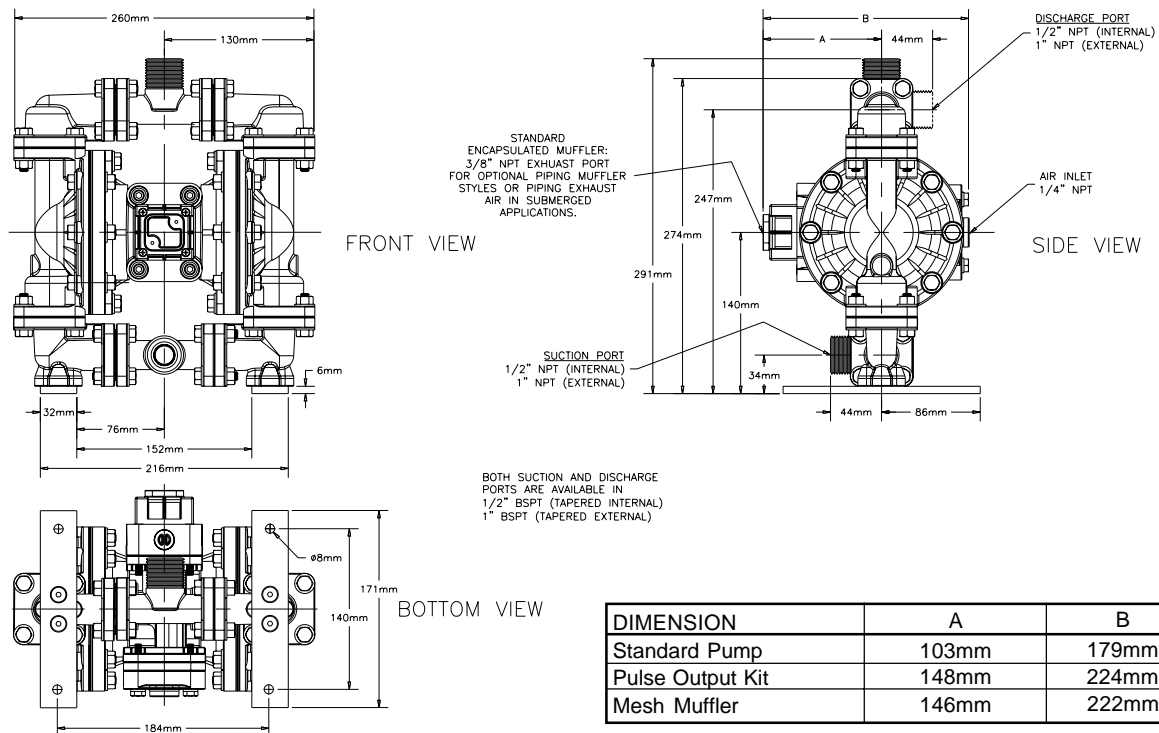

# Dimensions: S05 Metallic (Stainless Steel & Hastelloy Models)

Dimensions in Inches

Dimensional Tolerance:  $\pm 1/8"$

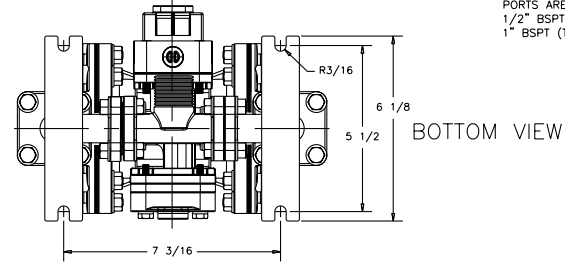
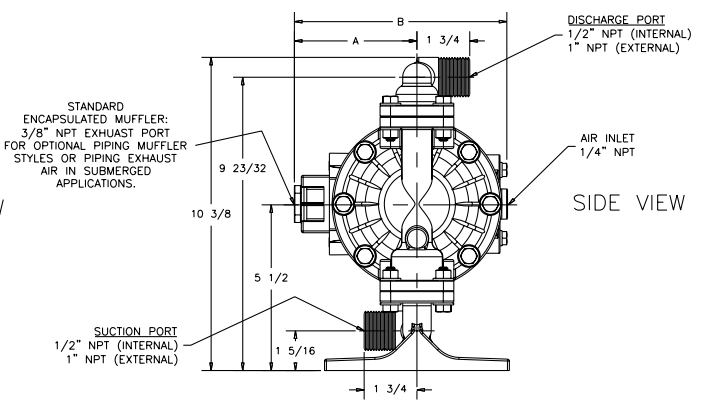
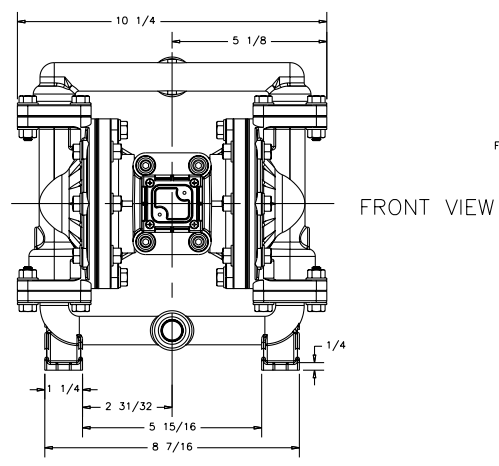

BOTH SUCTION AND DISCHARGE PORTS ARE AVAILABLE IN  
 1/2" BSPT (TAPERED INTERNAL)  
 1" BSPT (TAPERED EXTERNAL)

DIMENSION	A	B
Standard Pump	4 1/16"	7 1/16"
Pulse Output Kit	5 13/16"	8 13/16"
Mesh Muffler	5 3/4"	8 3/4"

Dimensions in Millimeters

Dimensional Tolerance:  $\pm 3\text{mm}$

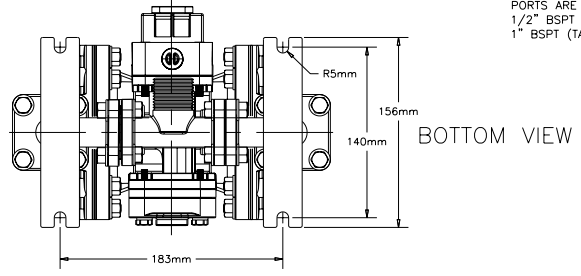
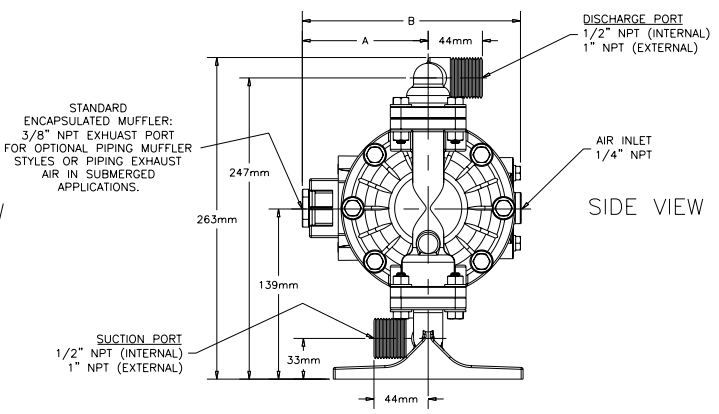
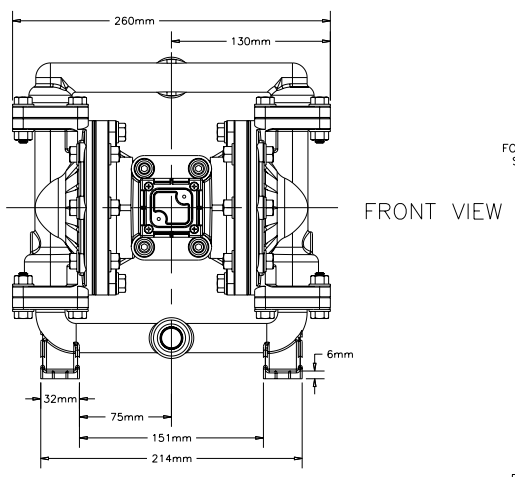

BOTH SUCTION AND DISCHARGE PORTS ARE AVAILABLE IN  
 1/2" BSPT (TAPERED INTERNAL)  
 1" BSPT (TAPERED EXTERNAL)

DIMENSION	A	B
Standard Pump	103mm	179mm
Pulse Output Kit	148mm	224mm
Mesh Muffler	146mm	222mm

